

# BYSON



[www.byson-intl.com](http://www.byson-intl.com)



# PUMBLING SPECIALITY

**0500** UNIVERSAL

4-1/4"

ZINC HANDLE  
BRASS ARM OR  
PLATED STEEL ARM  
ZINC NUT OR PLASTIC NUT

**0503** UNIVERSAL

8"

ZINC HANDLE  
BRASS ARM OR  
PLATED STEEL ARM  
ZINC NUT OR PLASTIC NUT

**0531** PUSH BUTTON

TANK LEVER  
FRONT MOUNT  
CHROME  
PLATED  
HANDLE

CP PLASTIC BODY

**0501** UNIVERSAL

8"

ZINC HANDLE  
BRASS ARM OR  
PLATED STEEL ARM  
ZINC NUT OR PLASTIC NUT

**0504** UNIVERSAL

8"

ZINC HANDLE  
BRASS ARM OR  
PLATED STEEL ARM  
ZINC NUT OR PLASTIC NUT

**0532** PUSH BUTTON

TANK LEVER SIDE MOUNT

CP PLASTIC BODY

CHROME  
PLATED  
HANDLE

**0536** UNIVERSAL

8"

ZINC HANDLE  
BRASS ARM OR  
PLATED STEEL ARM  
ZINC NUT OR PLASTIC NUT

**0515** FLAT ARM  
TANK LEVER

8"

ZINC HANDLE  
FLAT ARM  
PLASTIC NUT

**0552** TOTO

11"

ZINC HANDLE  
BRASS ARM OR  
PLASTIC NUT

FOR ST701 / CST854 / 884

**0502** UNIVERSAL

8"

ZINC HANDLE  
BRASS ARM OR  
PLATED STEEL ARM  
ZINC NUT OR PLASTIC NUT

**0511** FLAT ARM  
TANK LEVER

10" OFFSET FLAT BRASS ARM

CHROME  
PLATED  
HANDLE

ZINC NUT

**0553** TOTO

10"

ZINC HANDLE  
BRASS ARM OR  
PLASTIC NUT

FOR ST706

**0521** UNIVERSAL

4-1/4"

ZINC HANDLE  
BRASS ARM OR  
PLATED STEEL ARM  
ZINC NUT OR PLASTIC NUT

**0530** FLAT ARM  
TANK LEVER

8" OFFSET FLAT BRASS ARM

CHROME  
PLATED  
HANDLE

ZINC NUT

**0554** TOTO

10-1/2"

ZINC HANDLE  
BRASS ARM OR  
PLASTIC NUT

FOR ST743S

0533

KOHLER

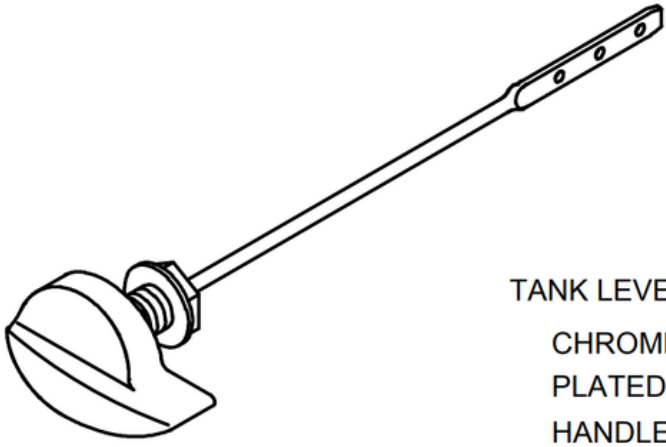

TANK LEVER  
CHROME  
PLATED  
HANDLE  
SIDE MOUNT

0507

KOHLER

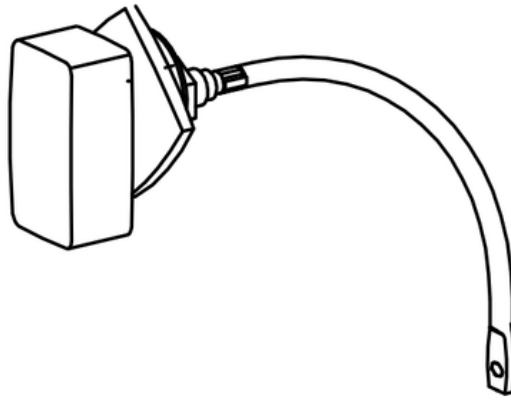

0505

MANSFIELD

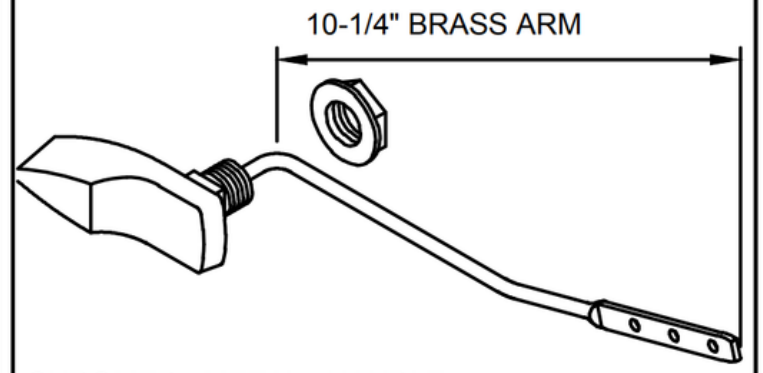

CHROMED METAL HANDLE  
MOULDED SPUD AND NUT

0535

KOHLER

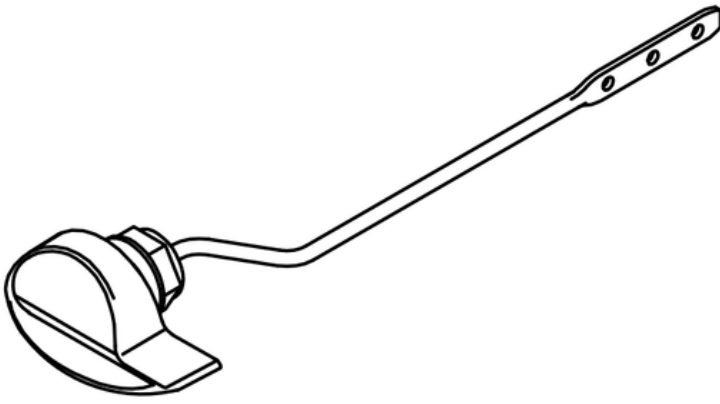

0519

KOHLER

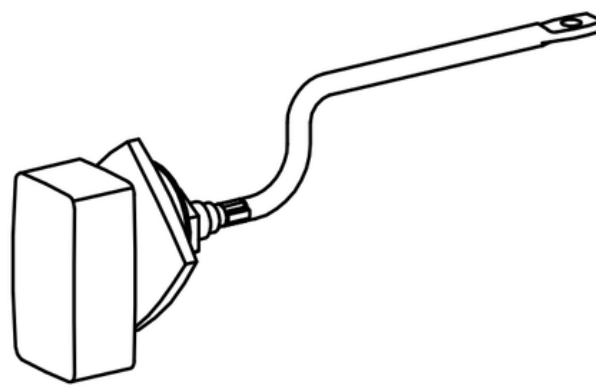

0520

MANSFIELD

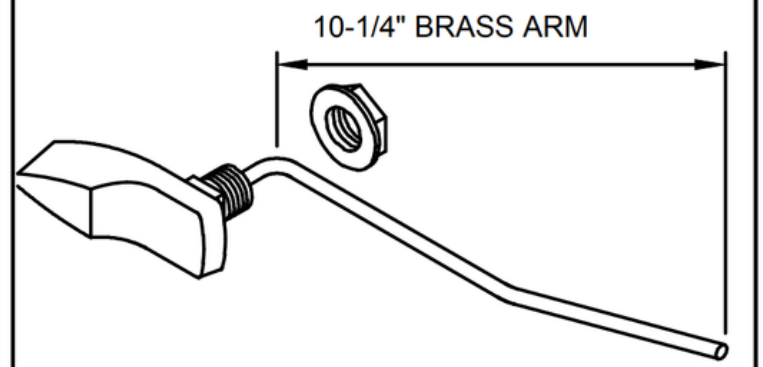

0540

KOHLER

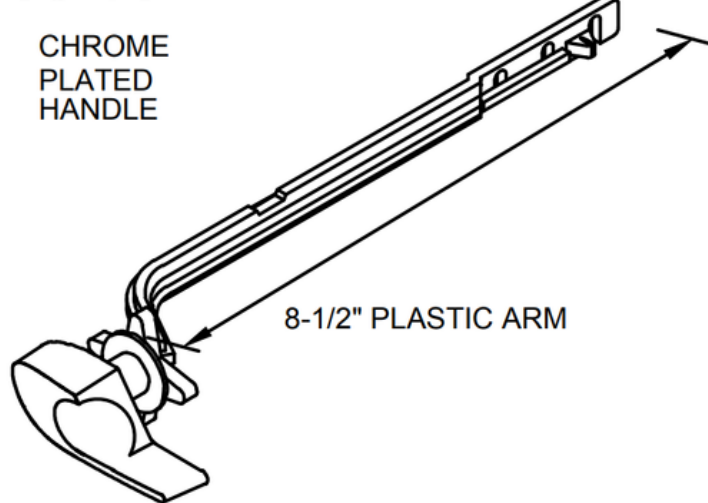

CHROME  
PLATED  
HANDLE

8-1/2" PLASTIC ARM

6201

ELJER TOILET  
FLUSH UNIT

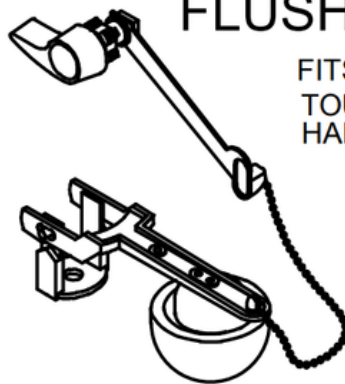

FITS ELJER  
TOUCH FLUSH  
HANDLE

Replacement for Eljer toilet touch flush unit  
Complete kit includes lock lever  
guide chain and rubber tank bar

0517

KOHLER

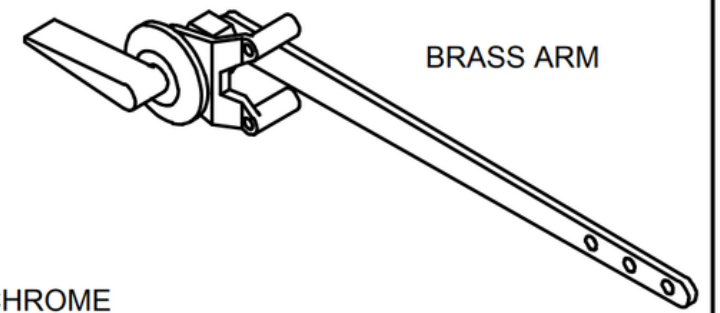

BRASS ARM

CHROME  
PLATED  
HANDLE

0541

KOHLER

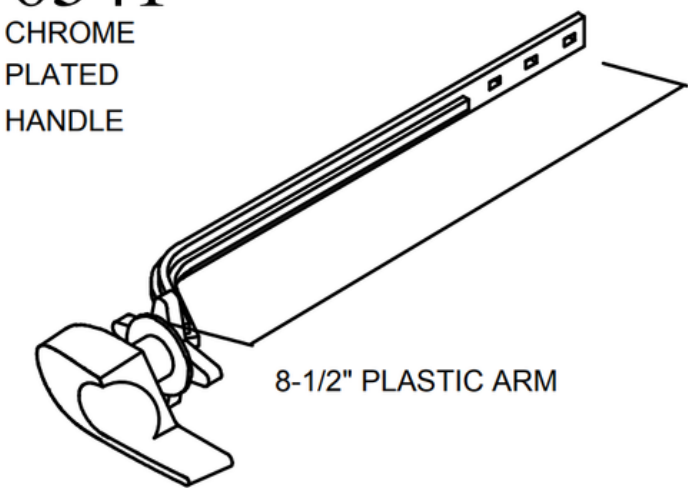

CHROME  
PLATED  
HANDLE

8-1/2" PLASTIC ARM

0534

ELJER

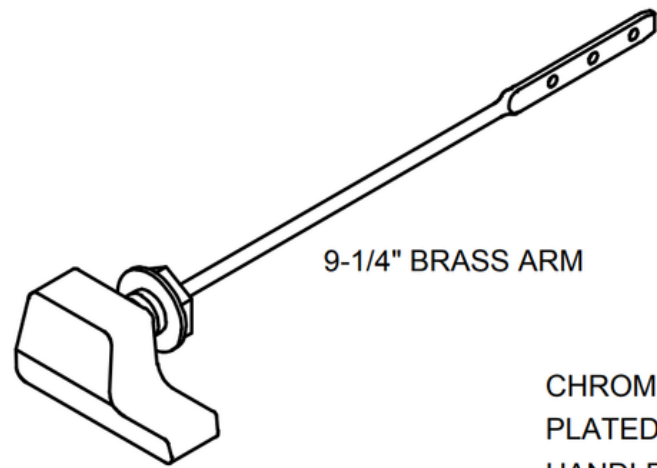

9-1/4" BRASS ARM

CHROME  
PLATED  
HANDLE

0557

GERBER

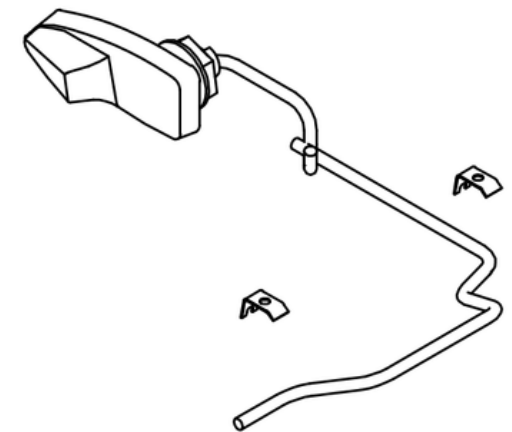

0542

KOHLER

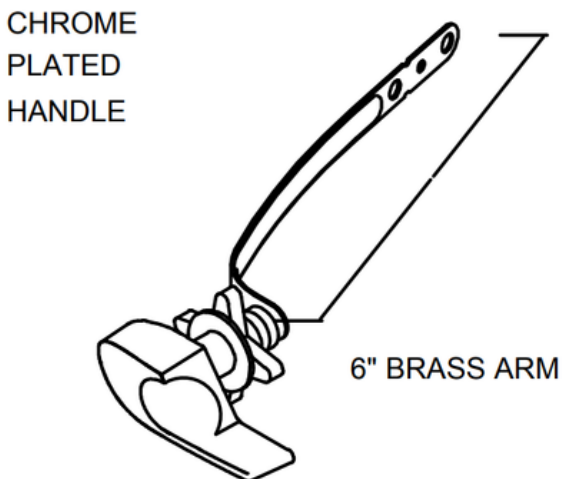

CHROME  
PLATED  
HANDLE

6" BRASS ARM

0555

ELJER

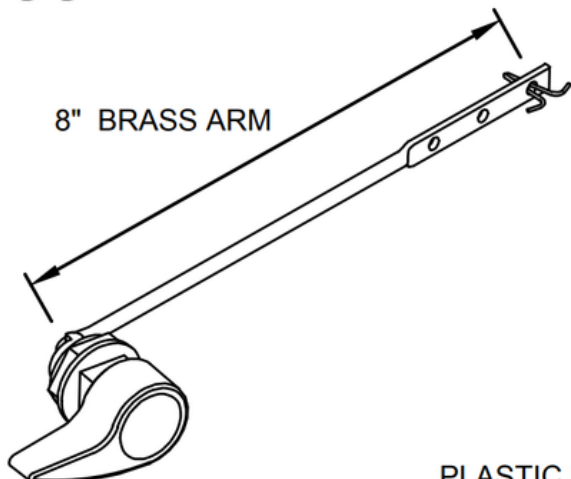

8" BRASS ARM

PLASTIC NUT

0506

GERBER

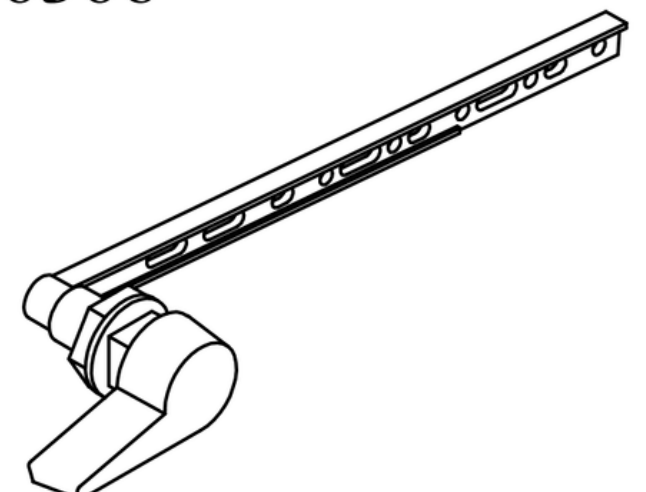

TANK LEVER

TANK LEVER

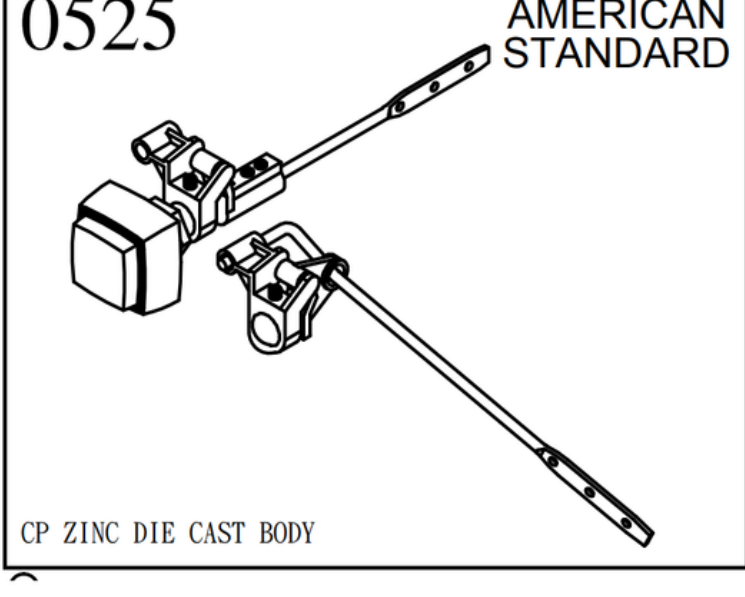
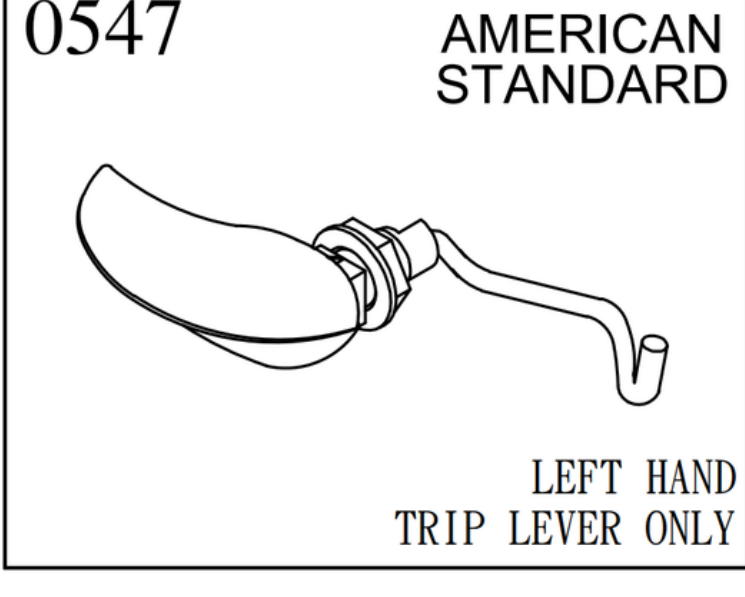
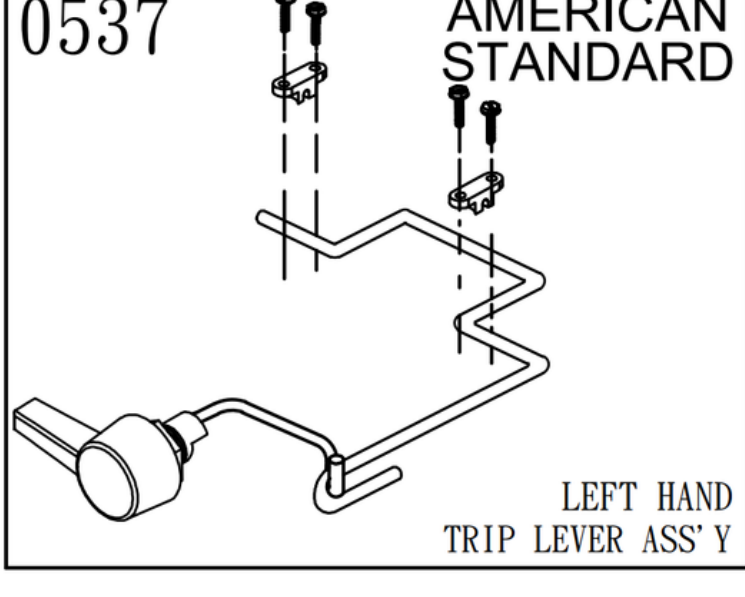
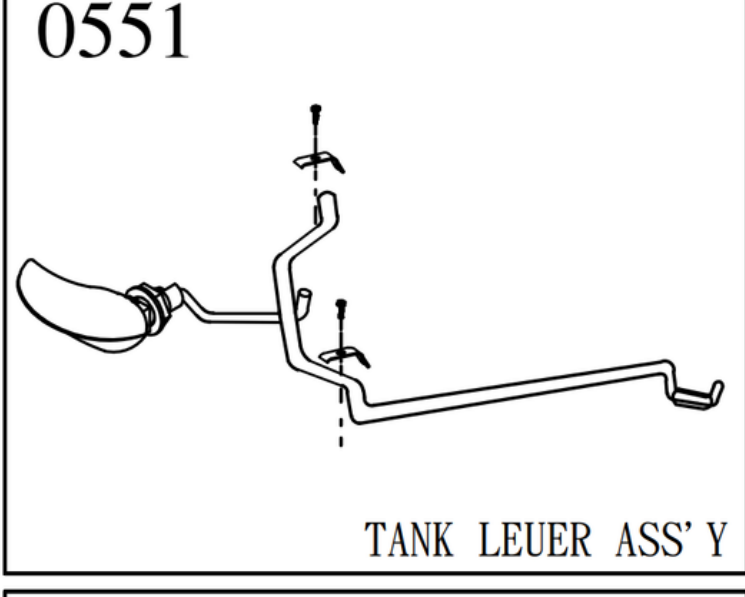
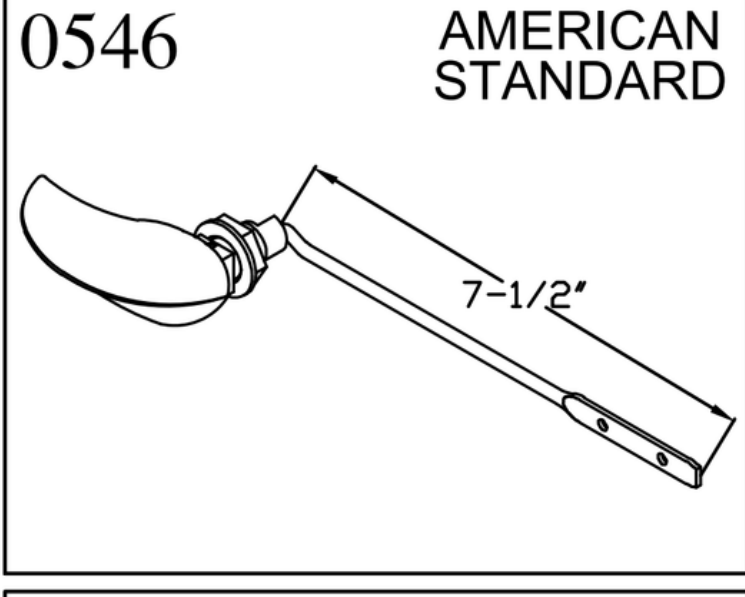
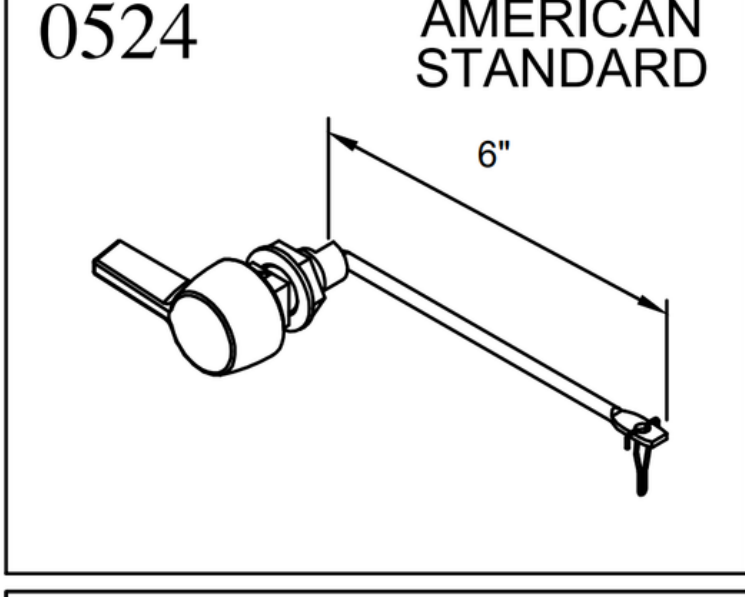
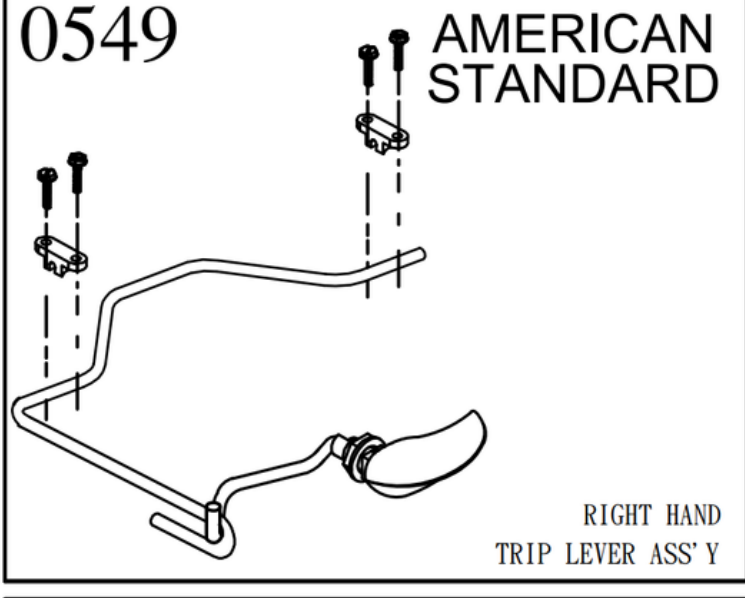
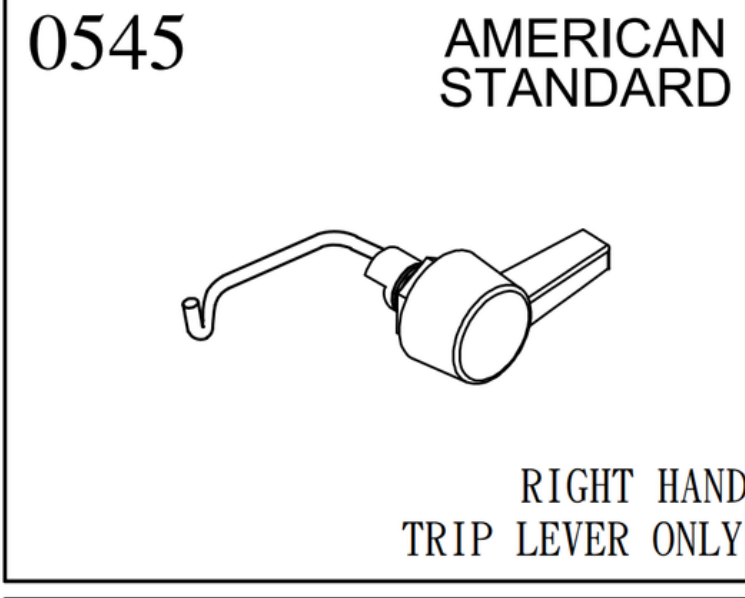
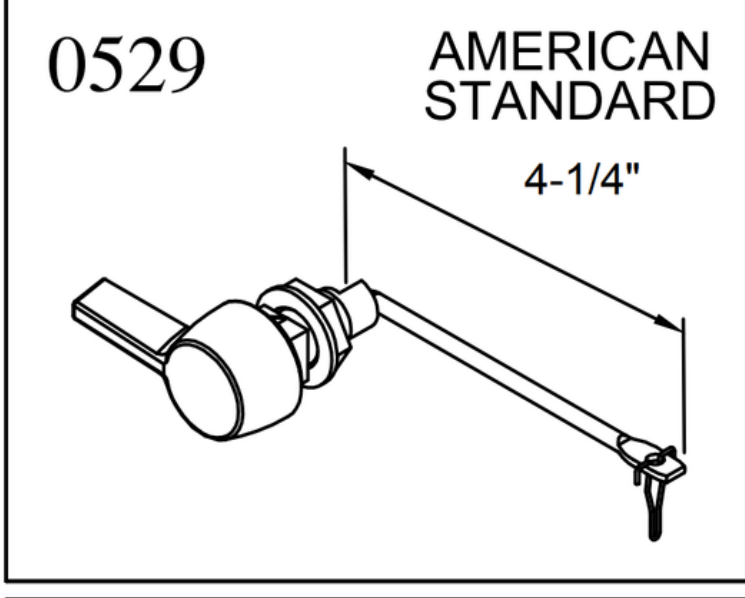
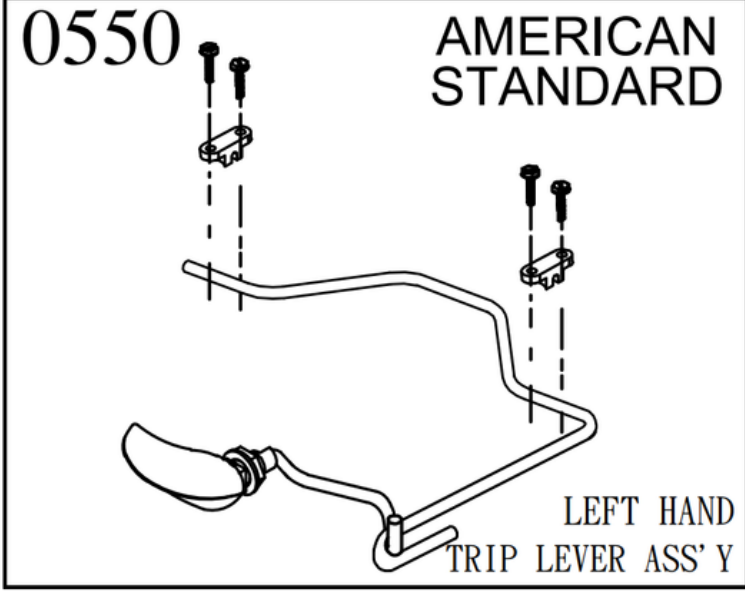
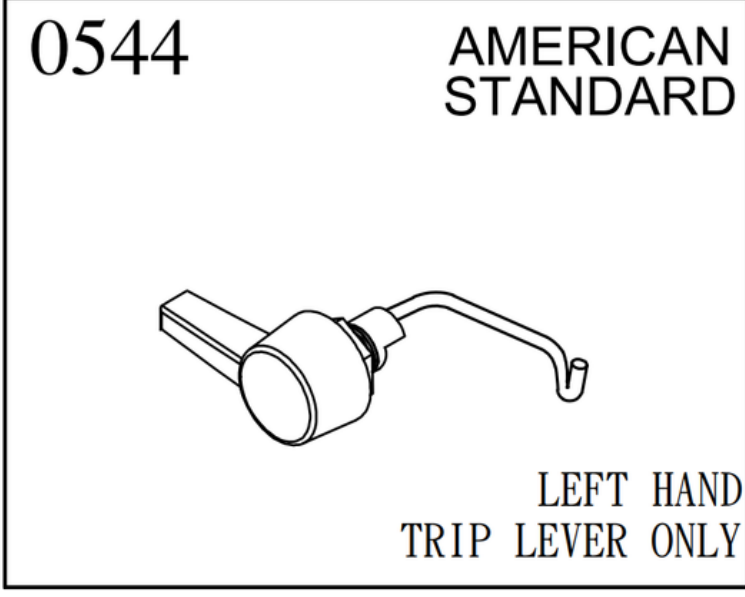
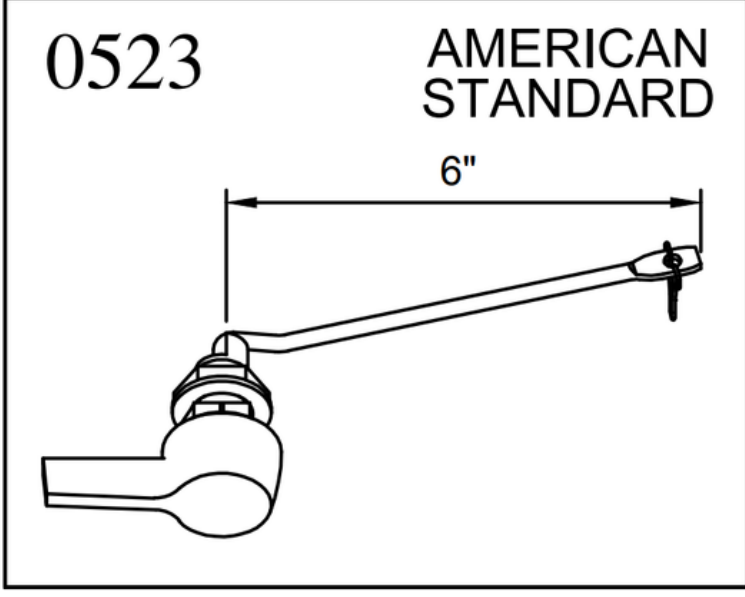
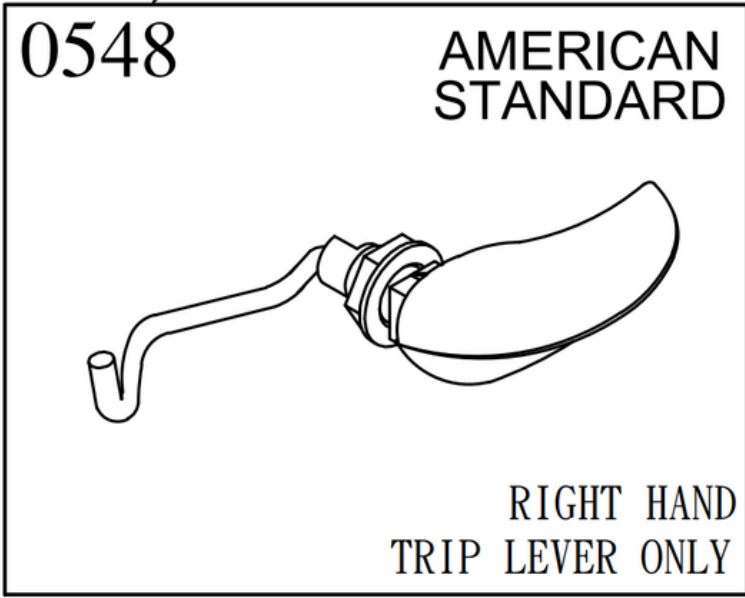
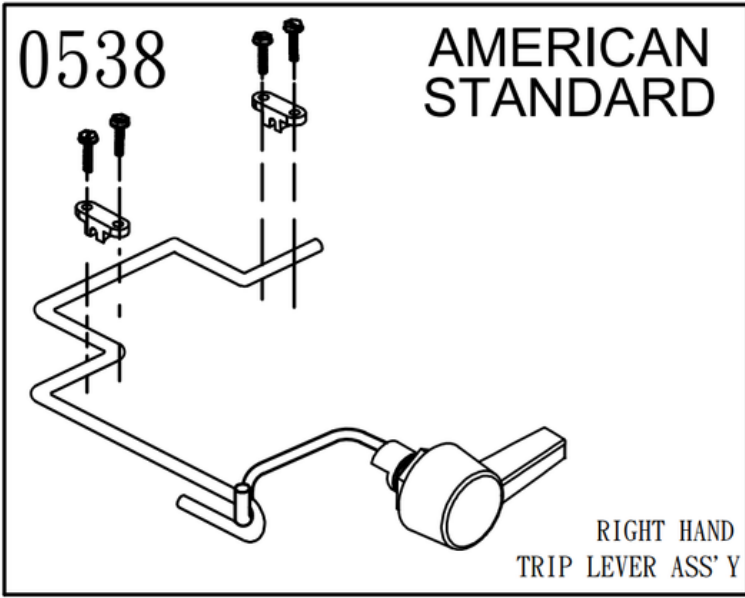
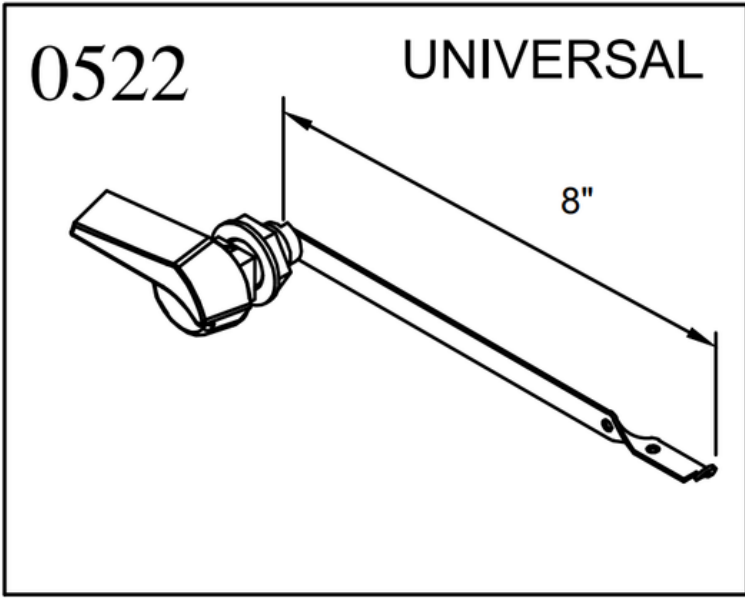

TANK LEVER

0526

AMERICAN STANDARD

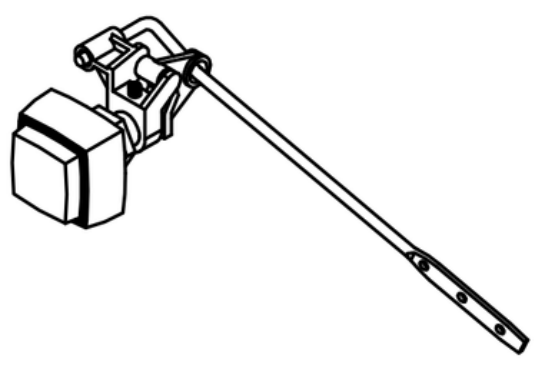

CP ZINC DIE CAST BODY

0527

AMERICAN STANDARD

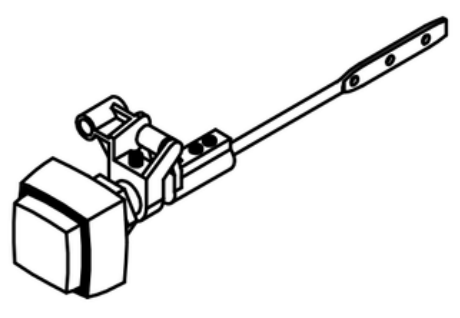

CP ZINC DIE CAST BODY

6101

AMERICAN STANDARD

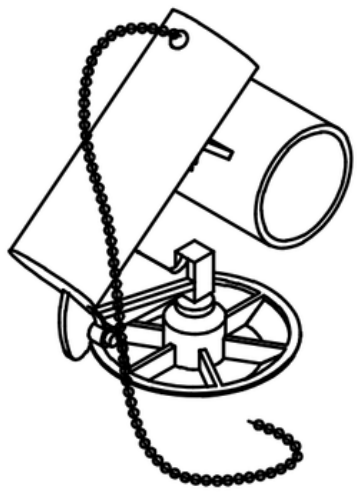

6111

AMERICAN STANDARD

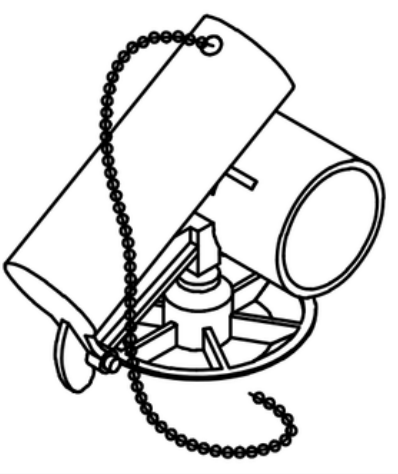

0543

BRIGGS VACUITY

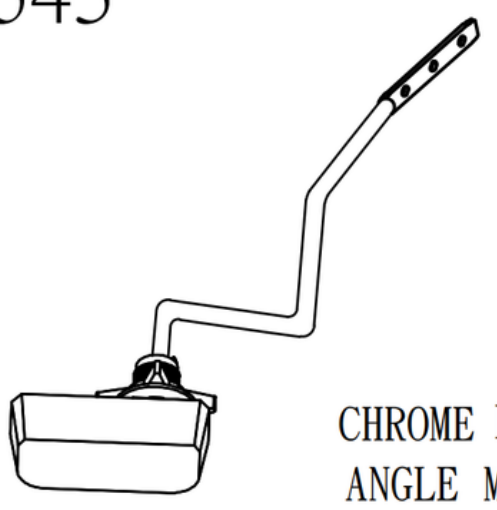

CHROME PLATED  
ANGLE MOUNT

TANK LEVER

0539

## FITS MOST TANK LEVER

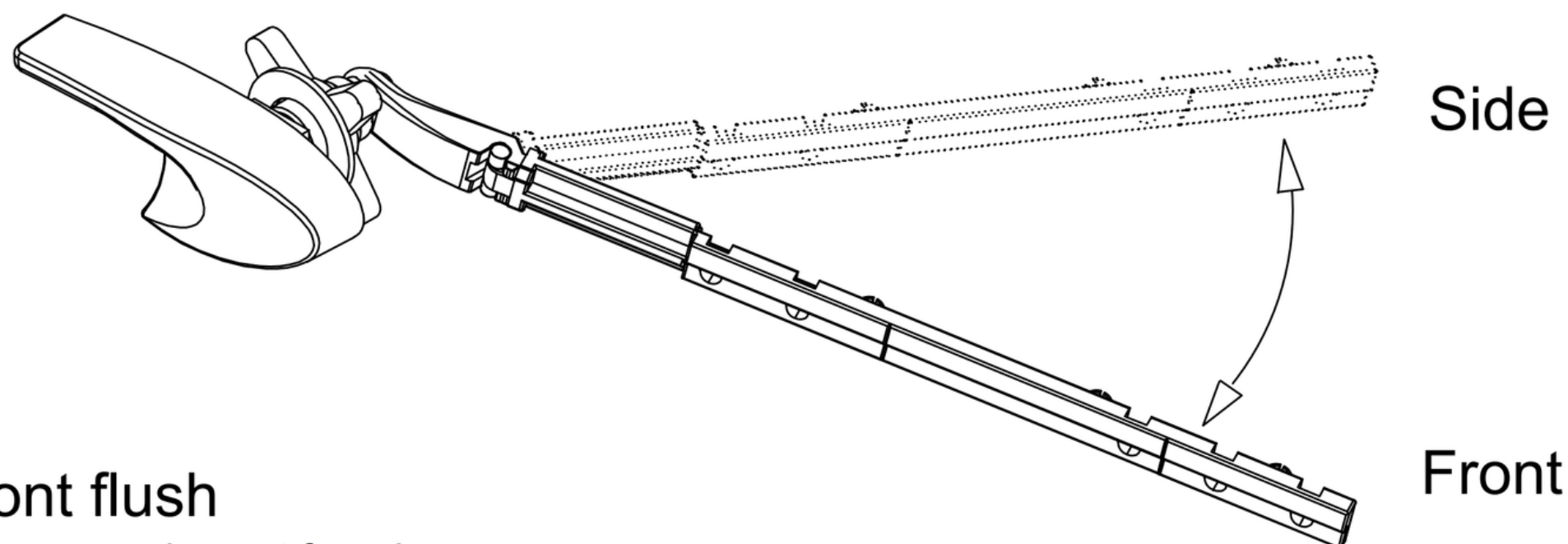

## Front flush

1. Remove wing nut from lever
2. Insert the lever through the hole on the front of the tank, the length can be adjusted accordingly, cut the lever at the pre-marked indicator to the intended length
3. Screw the wing nut onto lever to secure it in place
4. Attach the lift chain from the tank to the lever

## Side flush

1. Remove wing nut from lever
2. Bend the lever outward, note that the lever will fall apart when bend inward but can be easily put back together in the socket. When putting it back together the slots for the lift chain are pointed facing away
3. Insert the lever through the hole on the side of the tank, the length can be adjusted accordingly, cut the lever at the pre-marked indicator to the intended length
4. Screw the wing nut onto lever to secure it in place
5. Attach the lift chain from the tank to the lever

## Side flush 2.

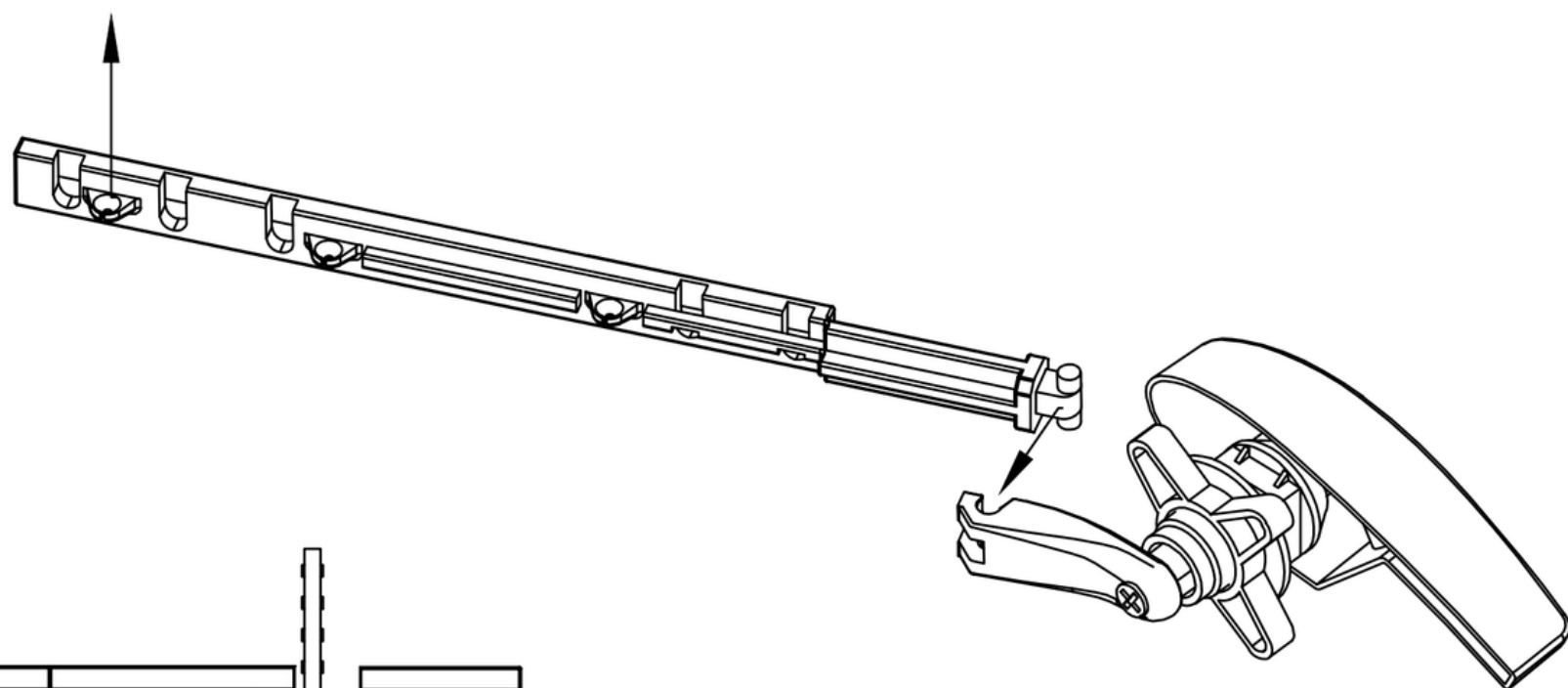

## Side flush 3.

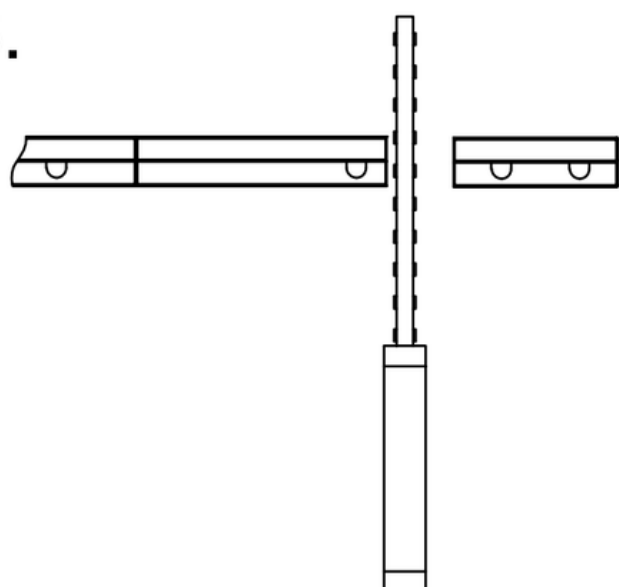

0556

FITS ALL TANK LEVER

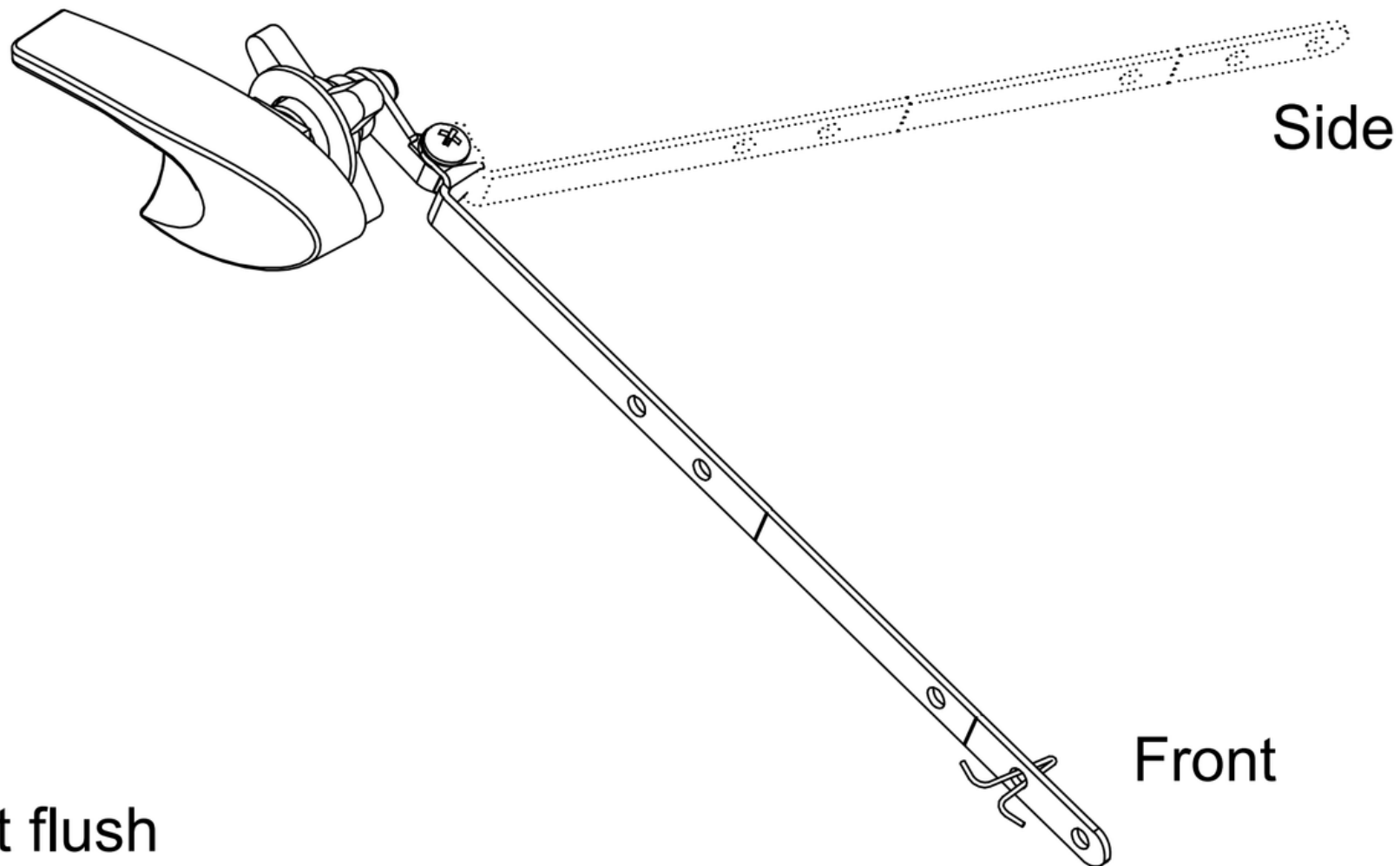

### Front flush

1. Remove wing nut from lever
2. Insert the lever through the hole on the front of the tank, the length can be adjusted accordingly, cut the lever at the pre-marked indicator to the intended length
3. Screw the wing nut onto lever to secure it in place
4. Attach the lift chain from the tank to the lever

### Side flush

1. Remove wing nut from lever
2. Bend the lever outward, adjust screw to need angle by screwdriver
3. Insert the lever through the hole on the side of the tank, the length can be adjusted accordingly, cut the lever at the pre-marked indicator to the intended length
4. Screw the wing nut onto lever to secure it in place
5. Attach the lift chain from the tank to the lever
6. For angled tanks bend rod slowly to dodge the obstacle if necessary

### Side flush 2.

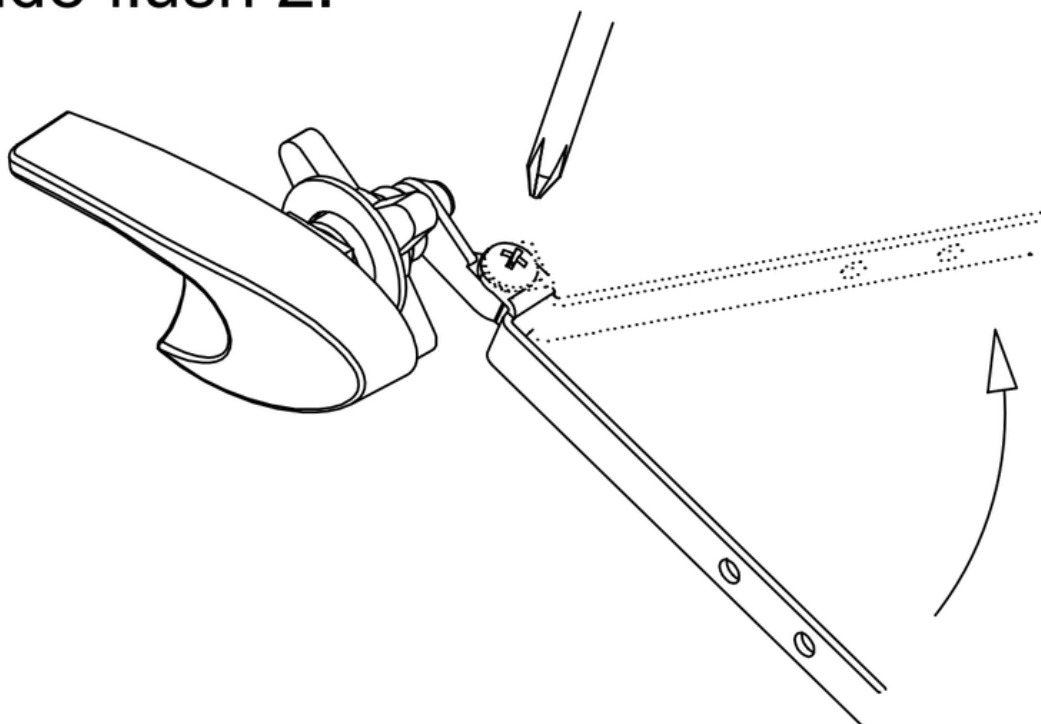

### Side flush 3.

